



GEZE PERKEO AND LINEAR GUIDES
THE BALL BEARING SLIDING DOOR SYSTEM
FOR EXTREMELY DURABLE, PRECISE GUIDES



CONTENTS

GEZE PERKEO – Ball bearing sliding door systems

PERKEO 75 sizes 1, 2, 3	4
Standard installation	5
PERKEO 75 sizes 1, 2, 3 – Ordering information	6
PERKEO 75 Type 14/ Type 14a	7
PERKEO sizes 1, 2, 4	8
Standard installation	9
PERKEO sizes 1, 2, 4 – Ordering information	10

GEZE Linear guides

Linear guides RP 75 and RP	11
Linear guides P 75 1, 2, 3	12
Linear guides P 1, 2, 4	14

GEZE PERKEO AND LINEAR GUIDES

GEZE PERKEO 75 sizes 1, 2, 3

The Perkeo ball bearing sliding door system is characterised by its tiny dimensions, yet capable of great payloads. The entire unit, with a compact and free of play linear ball bearing with axial main load direction, is suited for single and double leaf sliding door systems. Perkeo is used in situations when long-life, extreme durability and precise guides are required, for example, in the construction sector, in industrial systems or vehicle construction.

Product features

- Complete unit consisting of carrier rail and track, cage and ball bearings.
- Low friction value
- Compact design
- Swivel-mounted carrier plates

Application range

- For all sliding doors
- For all door materials
- Wall and ceiling attachment
- For high loads

Size 1: 100 or 140 kg*

Size 2: 150 or 190 kg*

Size 3: 200 or 250 kg*

- Carrier plates are swivel mounted, so hardware also suitable for inclined walls and ceilings. (see Fig. 04-2)

* 3 pcs. for leaves wider than 1500 mm

Standard version / Scope of delivery

Sliding door hardware, complete with buffers, hanger bolts, carrier plates, attachment angles, floor guide.

Size 1: carrier rail and track galvanized

Size 2 and 3: steel, polished

Special version

For a wide range of applications in the mechanical engineering, plant engineering, automotive and ship-building industries.



Fig. 04-1 PERKEO 75 size 1

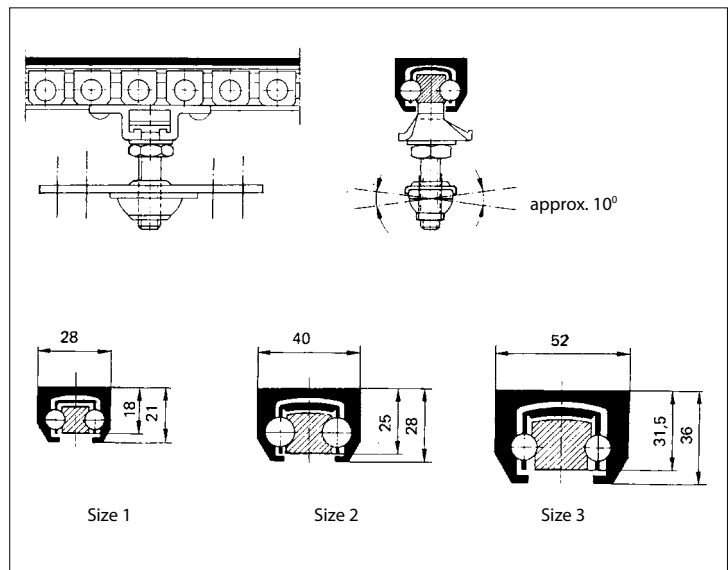

Fig. 04-2

GEZE PERKEO AND LINEAR GUIDES

Standard installation

Fig. 05-1 shows how the GEZE PERKEO 75 is installed to carry a single-leaf, wooden sliding door:

- 1) Buffer with base
- 2) Floor guide
- 3) Carrier plate, swivelling
- 4) Limit stop (standard)
- 5) Rubber buffer (on request)

The hardware is delivered with limit stops as standard. It can be fixed to the wall with attachment angles, or directly to the ceiling.

A second buffer must be installed on a level with the horizontal centreline of the door or at the bottom so that the door leaf is stopped simultaneously at the top and bottom.

Note:

Removable panels must be installed to permit access to wall recesses.

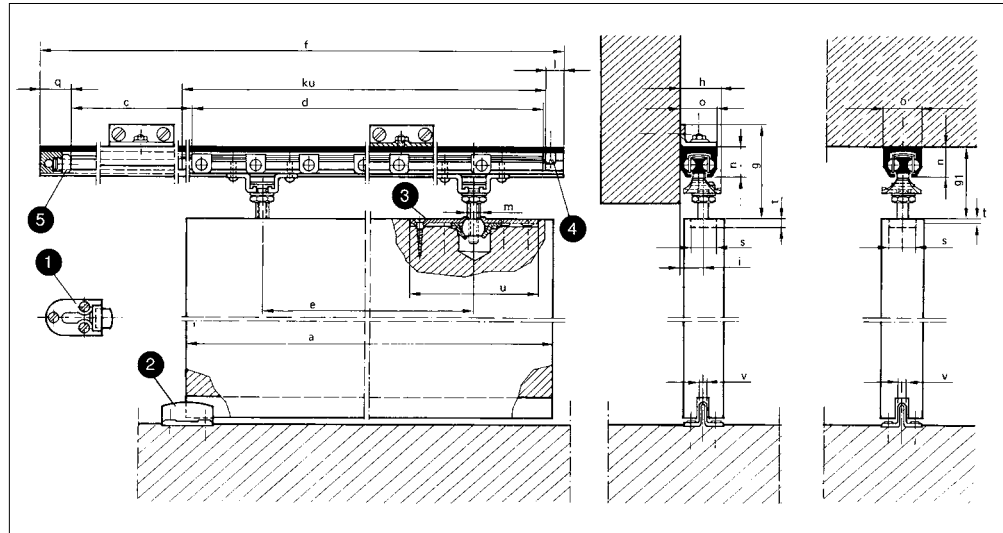

Fig. 05-1

Standard sizes (mm)

Leaf width a travel c	Length of carrier rail f		Length of track d		Carrier pitch e	Door weight max. kg		
	s. 1	s. 2-3	s. 1	s. 2-3		s. 1	s. 2	s. 3
310 - 400	740	750	310	310	210	100	150	200
410 - 500	892	910	362	370	260	100	150	200
510 - 600	1078	1090	448	450	320	100	150	200
610 - 700	1230	1240	500	500	350	100	150	200
710 - 800	1365	1390	535	550	390	100	150	200
810 - 900	1517	1540	587	600	440	100	150	200
910 - 1000	1686	1690	656	650	490	100	150	200
1010 - 1100	1821	1840	691	700	530	100	150	200
1110 - 1200	2041	2040	811	800	630	100	150	200
1210 - 1300	2176	2190	846	850	680	100	150	200
1310 - 1400	2345	2360	915	920	740	100	150	200
1410 - 1500	2497	2510	967	970	790	100	150	200
1510 - 1600	2649	2660	1019	1020	840	140	190	250
1610 - 1700	2835	2840	1105	1100	900	140	190	250
1710 - 1800	2987	3000	1157	1160	960	140	190	250
1810 - 1900	3173	3190	1243	1250	1050	140	190	250
1910 - 2000	3325	3340	1295	1300	1100	140	190	250

(3 suspension rods with e/2 pitch for leaves wider than 1500 mm)

GEZE PERKEO 75 sizes 1, 2, 3

Size	Range of adjustment (mm)			Installation sizes (mm)									
	Wall attachment		Ceiling attachment vertical	h	l	m	n	o	q	s	t	u	v
	lateral	vertical											
	i	g	g1										
1	12 - 22	63 - 76	48 - 61	31	15	M10	21	28	24	21	5,5	100	7
2	16 - 28	83 - 98	63 - 78	-	20	M12	28	40	33	26	5	150	7
3	19 - 37	96 - 111	71 - 86	-	20	M12	36	52	42	26	5	150	7

GEZE PERKEO AND LINEAR GUIDES

GEZE PERKEO 75 sizes 1, 2, 3 – Ordering information

Description	Leaf width (cm)	ID no. size 1	ID no. size 2	ID no. size 3
Ball bearing sliding door system GEZE PERKEO 75	31 - 40	014338	on request	on request
	41 - 50	014339		
	51 - 60	014340		
	61 - 70	014341		
	71 - 80	014342		
	81 - 90	014343		
	91 - 100	014344		
	101 - 110	014345		
	111 - 120	014346		
	121 - 130	014347		
	131 - 140	014348		
	141 - 150	014349		
	151 - 160	014350		
	161 - 170	014351		
	171 - 180	014352		
	181 - 190	014353		
	191 - 200	014354		

GEZE PERKEO 75 Type 14/Type 14a

This system for double-leaf applications is based on PERKEO 75. It is available as a synchronized (Type 14a) and a non-synchronized (Type 14) version.

Product features

- Two tracks fixed inside a carrier rail
- Type 14 without wire-rope coupling
- Type 14a with wire-rope coupling

Application range

- For double-leaf doors
- Type 14 wall and ceiling attachment
- Type 14a wall attachment

Note:

Removable panels must be installed to permit access to wall recesses.

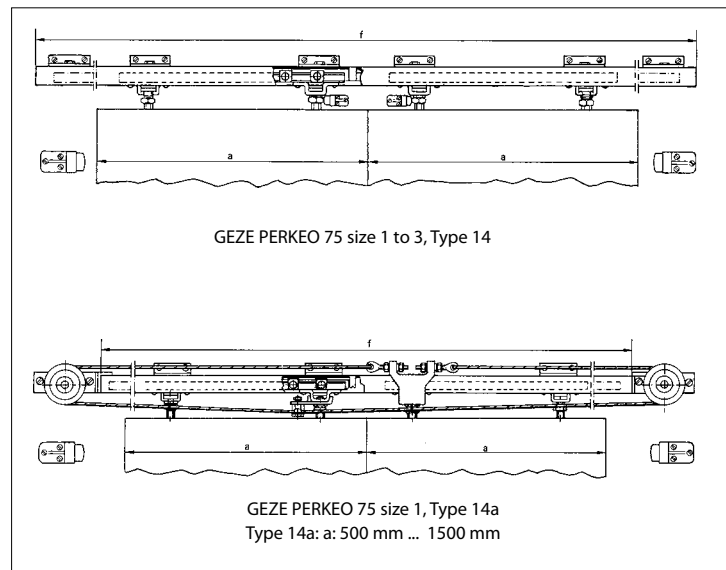

Fig. 07-1

PERKEO 75	Weight of each leaf		
	s. 1	s. 2	s. 3
Type 14	100	150	200
Type 14a	75	-	-

Ordering information

Description	
GEZE PERKEO 75 size 1, Type 14	Width of each leaf ... cm wall and ceiling attachment
GEZE PERKEO 75 size 1, Type 14a	with wire-rope coupling for double-leaf doors wall attachment

GEZE PERKEO AND LINEAR GUIDES

GEZE PERKEO sizes 1, 2, 4

GEZE PERKEO is a compact linear ball bearing system with axial major direction of loading for single-leaf and double-leaf sliding doors. The system is always used when long-lasting heavy duty precision guides will be in demand, for example in the construction sector, in industrial systems or vehicle construction.

Product features

- Complete unit, consisting of carrier rail and track, cage and ball bearings
- Low friction
- Compact design
- Swivelling carrier plates (size 1-2)
- Steel polished;
galvanized finish to customer specification

Application range

- For all sliding doors
- For all door materials, e. g. wood, metal, unframed glass
- Wall attachment
- Ceiling attachment to customer specification
- For high loads:
Size 1: 75 or 100 kg*
Size 2: 100 or 140 kg*
Size 4: 240 or 360 kg*
- With swivelling carrier plates (sizes 1-2) the system can also be used for inclined walls or ceilings (see Fig. 08-2)

* 3 pcs. for leaves wider than 1500 mm

Standard version / Scope of delivery

Sliding door hardware complete with buffers, hanger bolts, carrier plates, floor guide, polished steel.

Special version

Available for a wide range of applications in the mechanical engineering, plant engineering and automotive industries: please state intended use.



Fig. 08-1 PERKEO size 1

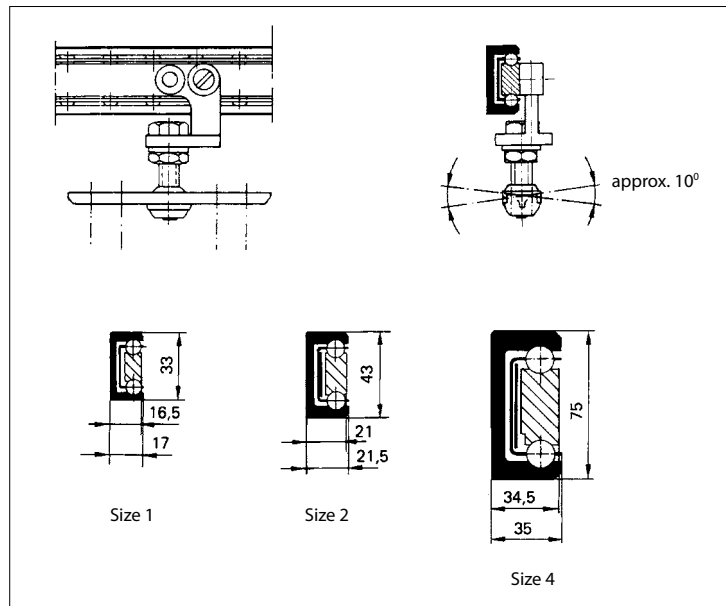

Fig. 08-2

GEZE PERKEO AND LINEAR GUIDES

Standard installation

Fig. 09-1 shows how the GEZE PERKEO is installed to carry a single-leaf wooden sliding door:

- 1) Buffer with base
- 2) Floor guide
- 3) Carrier plate, swivelling (2 pcs.)
- 4) Limit stop
- 5) Rubber buffer (on request)

The hardware may be fixed directly to the wall or to the ceiling with the aid of attachment angles.

A second buffer must be installed on a level with the horizontal centreline of the door or at the bottom, so that the door leaf is stopped simultaneously at the top and bottom.

Note:

Removable panels must be installed to permit access to wall recesses.

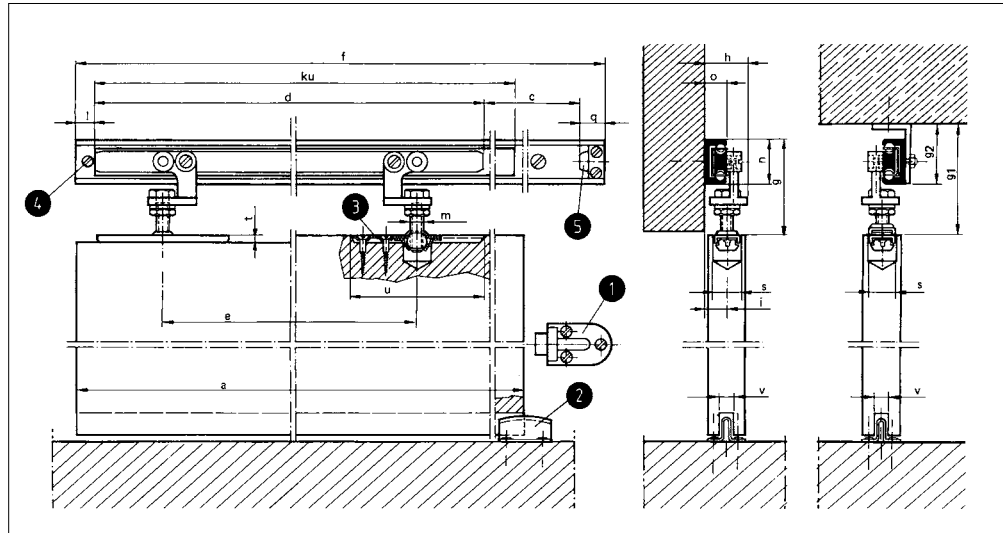

Fig. 09-1

Standard sizes (mm)

Leaf width a travel c	Length of carrier rail f		Length of track d		Carrier pitch e	Door weight max. kg		
	s. 1	s. 2/4	s. 1	s. 2/4		s. 1	s. 2	s. 4
310 - 400	740	750	310	310	210	75	100	240
410 - 500	892	910	362	370	260	75	100	240
510 - 600	1078	1090	448	450	320	75	100	240
610 - 700	1230	1240	500	500	350	75	100	240
710 - 800	1365	1390	535	550	390	75	100	240
810 - 900	1517	1540	587	600	440	75	100	240
910 - 1000	1686	1690	656	650	490	75	100	240
1010 - 1100	1821	1840	691	700	530	75	100	240
1110 - 1200	2041	2040	811	800	630	75	100	240
1210 - 1300	2176	2190	846	850	680	75	100	240
1310 - 1400	2345	2360	915	920	740	75	100	240
1410 - 1500	2497	2510	967	970	790	75	100	240
1510 - 1600	2649	2660	1019	1020	840	100	140	360
1610 - 1700	2835	2840	1105	1100	900	100	140	360
1710 - 1800	2987	3000	1157	1160	960	100	140	360
1810 - 1900	3173	3190	1243	1250	1050	100	140	360
1910 - 2000	3325	3340	1295	1300	1100	100	140	360

GEZE PERKEO sizes 1, 2, 4

Size	Wall attachment		Ceiling attachment											
	lateral	vertical	g1	g2	h	l	m	n	o	q	s	t	u	v
1	13 - 24	59 - 75	72 - 88	45	34	15	M10	33	17	18	21	5,5	100	7
2	15 - 24	70 - 78	87 - 95	60	37	20	M12	43	21,5	25	26	5	150	7
4	31 - 40	113 - 133	140 - 160	100	57	20	M16	75	35	32	30	8	175	7

GEZE PERKEO AND LINEAR GUIDES

GEZE PERKEO sizes 1, 2, 4 – Ordering information

Description	Leaf width (cm)	Size 1	Size 2	Size 4
Ball bearing sliding door system GEZE PERKEO	31 - 40	on request	on request	on request
	41 - 50			
	51 - 60			
	61 - 70			
	71 - 80			
	81 - 90			
	91 - 100			
	101 - 110			
	111 - 120			
	121 - 130			
	131 - 140			
	141 - 150			
	151 - 160			
	161 - 170			
	171 - 180			
	181 - 190			
191 - 200				
Accessories for GEZE PERKEO				
Ceiling attachment angles	separate, number of attachment angles depends on size and leaf width			

GEZE Linear guides RP 75 and RP

Product features

- Linear roller guide.
The rolls will be moved in the required direction and in the same time the load is borne.
- Roller carriage with carrier and guide rolls
- Deadlock-free and smooth running
- Minor starting resistance
- The guidance consists of a bearing rail and roller carriage with minimum two track supporting rollers and two ball-bearing guide pulleys.
- Several roller carriages per bearing rail possible
- Small installation dimensions
- Easy and uncomplicated installation
- Low frictional coefficient
- Stroke limitation via built-in buffer on request
- Radial roller loads:

RP 75-1	=	150 N
RP-1	=	200 N
RP-2	=	600 N
RP-4	=	1000 N (single roller carriage)

 rolls for RP-2 even with plastic casing (load on request).

Application range

For cases in which an accurate guide for feed and stroke is needed. Particularly suitable for vertical guides and for short sliding parts with long travel as well as for multiple sliding parts in one carrier rail.

Standard version

Made of blank steel. On request the guides can be delivered galvanised (rolls of blank steel only). The linear guide RP-2 is even available as vertical version.

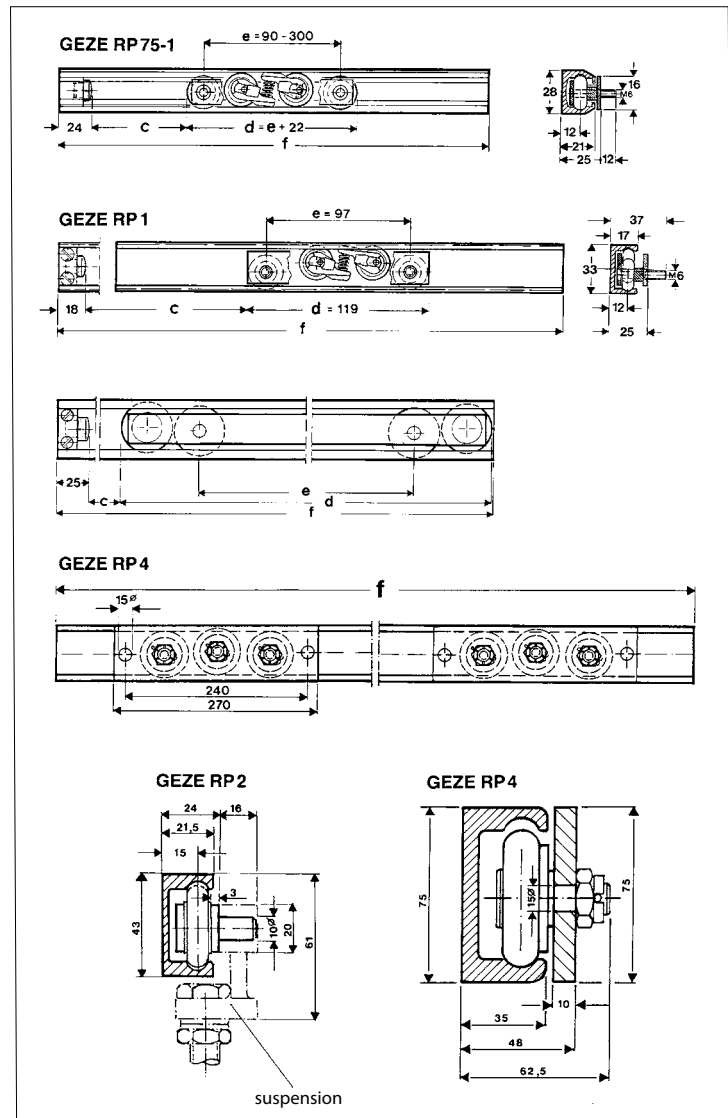

Fig. 11-1

Legend

- c = travel (stroke)
- d = length of roller carriage
- e = suspension clearance
- f = length of carrier rail

GEZE PERKEO AND LINEAR GUIDES

GEZE Linear guides P 75, 1, 2, 3

Product features

- Linear parallel guide.
The structural units will be moved in the required direction and in the same time the load is borne.
- The guidance consists of carrier rail and track with steel balls which are guided between, according to the principle of elongated ball-bearing.
- Ball-bearing carrier guides and tracks assure a deadlock-free running by means of a low friction coefficient and minor starting resistance.
- Small installation dimensions
- Easy and uncomplicated installation
- Low frictional coefficient
- Stroke limitation by built-in buffer

Application range

For cases in which a high load capacity and an accurate heading or stroke movement is needed.

Standard version

Made of blank steel and galvanised on request.

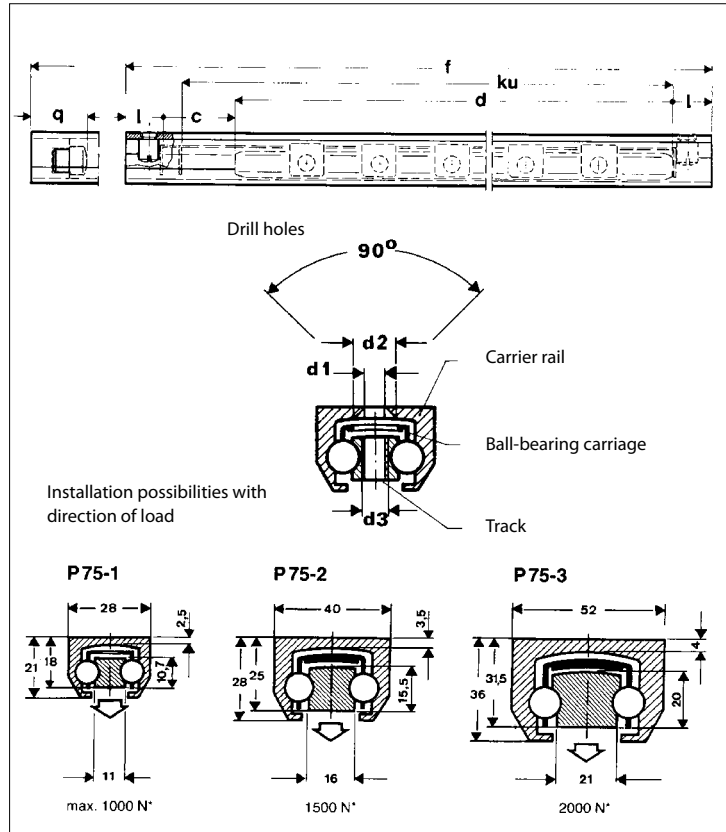

Fig. 12-1

Legend

- c = travel (stroke)
- d = length of track
- f = length of carrier rail
- ku = length of ball-bearing carriage
- kug = length of ball-bearing carriage + extension on both sides to make possible to bend the ends of the ball-bearing carriage (dimension definition by GEZE)
- l = dimension of limit stop
- q = built-in buffer

GEZE PERKEO AND LINEAR GUIDES

Calculation formula

$$f = c+d+2l$$

$$f = c+d+2q$$

$$ku = c/2+d$$

(the dimensions c and d must be specified when ordering)

Note:

$$f = \text{max. } 5500 \text{ mm}$$

(greater lengths on request)

With P75-1 ku must be divisible by 17.

Balance of dimensions by c or d.

With P75-2 and 3 the partition of the ball-bearing carriage can be chosen arbitrarily (max. 86 mm).

With rough strain (agitations) and at a very short track length (d) less than approx. 250 mm, the balls (partition) will be tight (must be specified when ordering).

If limiting is desired, please state type of limiter.

The limit stops serve only the protection of the ball-bearing carriage and cannot be used for stroke limiting.

If drill holes in the carrier rail or in the track are desired these drill holes must be specified within a sketch.

For hole spacing choose modular dimensions of 50 mm (e.g. 50, 100, 150 usw.) if possible.

Without specification the carrier guide and track will be delivered unbored.

Dimension	P 75-1	P 75-2	P 75-3
l = limit stop (mm)	15	20	20
q = built-in buffer (mm)	24	33	42
d1 (mm)	5,3	6,4	8,4
d2 (mm)	10,4	12,4	17,2
d3 standard	M5	M8	M8
d3 max.	M5	M8	M10

Weight (kg)	P 75-1	P 75-2	P 75-3
f = carrier guide by metre	1,410	3,430	5,000
d = track by metre	0,580	1,750	2,900
ku = ball-bearing carriage with 10 ball holders and 20 balls	0,182	0,320	0,468

Load max. (N)	P 75-1	P 75-2	P 75-3
These specifications are only valid with centric vertically load and with a track length d of min. 350 mm for P 75-1 min. 500 mm for P 75-2	1000	1500	2000
* for track length d = 1000 mm	1400	1900	2500

GEZE PERKEO AND LINEAR GUIDES

GEZE Linear guides P 1, 2, 4

Product features

- Linear parallel guide.
The structural units will be moved in the required direction and in the same time the load is borne.
- The guidance consists of carrier rail and track with steel balls which are guided between, according to the principle of a ball-bearing.
- Ball-bearing carrier guides and track assure a deadlock-free running by means of a low friction coefficient and minor starting resistance.
- Small installation dimensions
- Easy and uncomplicated installation
- Low frictional coefficient
- Stroke limitation by built-in buffer

Application range

For cases in which a high load capacity and an accurate heading or stroke movement is needed.

In special design the linear guides can be delivered in inward and outward bent version with a radius of curvature R: ... mm

Standard version

Made of blank steel and galvanised on request.

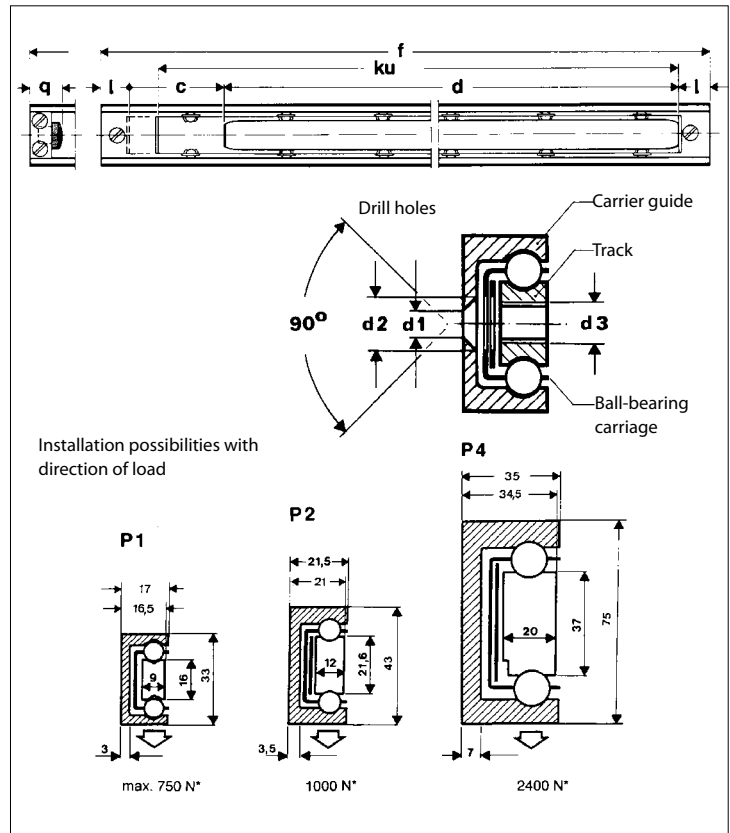

Fig. 14-1

Legend

- c = travel (stroke)
- d = length of track
- f = length of carrier guide
- ku = length of ball-bearing carriage
- kug = length of ball-bearing carriage + extensions on both sides to make possible to bend the ends of the ball-bearing carriage (dimension definition by GEZE)
- l = dimension of limit stop
- q = built-in buffer

GEZE PERKEO AND LINEAR GUIDES

Calculation formula

$$f = c+d+2l$$

$$f = c+d+2q$$

$$ku = c/2+d$$

(the dimensions c and d must be specified when ordering)

Note:

$$f = \text{max. } 5500 \text{ mm}$$

(greater lengths on request)

With P-1 ku must be divisible by 17.

Balance of dimensions by c or d.

With P-2 the partition of the ball-bearing carriage can be chosen arbitrarily (max. 86 mm).

With rough strain (agitations) and at very short track lengths (d) less than approx. 250 mm, the balls (partition) will be tight (must be specified when ordering).

If limiting is desired, please state type of limiter.

The limit stops serve only the protection of the ball-bearing carriage and cannot be used for stroke limiting.

If drill holes in the carrier rail or in the track are desired these drill holes must be specified within a sketch.

For hole spacing choose modular dimensions of 50 mm (e.g. 50, 100, 150 usw.) if possible.

Without specification the carrier guide and track will be delivered unbored.

Dimensions	P 1	P 2	P 4
l = limit stop (mm)	15	20	20
q = built-in buffer (mm)	18	25	32
d1 (mm)	5,3	6,4	10,5
d2 (mm)	10,4	12,4	21,5
d3 standard	M6	M8	M12
d3 max.	M8	M10	M20

Weight (kg)	P 1	P 2	P 4
f = carrier guide by metre	1,400	2,590	8,050
d = track by metre	0,860	1,860	5,220
ku = ball-bearing carriage with 10 ball holders and 20 balls	0,193	0,421	1,195

Load max. (N)	P 1	P 2	P 4
These specifications are only valid with centric vertically load and with a track length d of min. 350 mm for P 1 min. 500 mm for P 2 and P 4	750	1000	2400
* from track length d = 1000 mm	1000	1400	3600

You will find more product information in the relevant brochures, see ID numbers.

Door technology

01	Overhead door closers ID 091593, ID 091594
02	Hold-open systems ID 091593, ID 091594
03	Integrated door closers ID 091609
04	Floor springs ID 091607
05	Sliding door gear systems and linear guides ID 123605, ID 008770, ID 000586

Automatic door systems

06	Swing doors ID 144785
07	Sliding, telescopic and folding doors ID 143639
08	Circular and semi-circular sliding doors ID 135772
09	Revolving doors ID 132050
10	Actuation devices and sensors ID 142655

Smoke and heat extraction and window technology

11	Fanlight opening systems ID 127787
12	Electric opening and locking systems ID 154851
13	Electrical spindle and linear drives ID 154851
14	Electric chain drives ID 154851
15	Smoke and heat extraction systems ID 154851

Safety technology

16	Emergency exit systems ID 132408
17	Access control systems ID 132158
18	Panic locks ID 132848
19	Electric strikes ID 148666
20	Building management system ID 132408

Glass systems

21	Manual sliding wall systems (MSW) ID 104377
22	Integrated all-glass systems (IGG) ID 104366
23	GEZE Patch fittings mono glass systems ID 122521



POTENTIAL APPLICATIONS OF GEZE PRODUCTS



Door technology

The functionality, superior performance and reliability of GEZE door closers are impressive. A common design across the range, the ability to use them on all common door leaf widths and weights, and the fact that they can be individually adjusted makes their selection simple. They are continually being improved and enhanced with up-to-date features. For example, the requirements of fire protection and accessibility are fulfilled with a door closer system.

Automatic door systems

GEZE automatic door systems open up a huge variety of options in door design. The latest, innovative high-performance drive technology, safety, ease of accessibility and first class universal drive design set them apart. GEZE offers complete solutions for individual requirements. A dedicated division is responsible for the development and construction of individual special designs.

Smoke and heat extraction and window technology

GEZE smoke and heat extraction systems and ventilation technology provide complete systems solutions combining the many requirements of different types of windows. We supply a full range from energy efficient drive systems to natural ventilation and complete solutions for supplying and extracting air, also as certified SHEVs.

Safety technology

GEZE safety technology sets the standards where preventative fire protection, access control and anti-theft security in emergency exits are concerned. For each of these objectives GEZE offers tailored solutions, which combine the individual safety requirements in one intelligent system and close doors and windows in case of danger in a coordinated manner.

Building systems

In GEZE's Building Management System GEZE door, window and safety products can be integrated in to the security and control systems of the building. A central control and visualisation system monitors various automation components in the building and offers security through many different networking capabilities.

Glass systems

GEZE glass systems stand for open and transparent interior design. They can either blend discreetly into the architecture of the building or stand out as an accentuated feature. GEZE offers a wide variety of technologies for functional, reliable and aesthetic sliding wall or sliding door systems providing security with lots of design scope.

GEZE GmbH
P.O. Box 1363
71226 Leonberg
Germany

GEZE GmbH
Reinhold-Vöster-Straße 21-29
71229 Leonberg
Germany
Telefon +49 (0) 7152-203-0
Telefax +49 (0) 7152-203-310
www.geze.com

Germany
GEZE Sonderkonstruktionen GmbH
 Planken 1
 97944 Boxberg-Schweigern
 Tel. +49 (0) 7930-92 94-0
 Fax +49 (0) 7930-92 94-10
 sk.de@geze.com

GEZE GmbH
 Niederlassung Süd-West
 Breitwiesenstraße 8
 71229 Leonberg
 Tel. +49 (0) 7152-203-594
 Fax +49 (0) 7152-203-438
 leonberg.de@geze.com

GEZE GmbH
 Niederlassung Süd-Ost
 Parking 17
 85748 Garching bei München
 Tel.: +49 (0) 89-120 07 42-50
 Fax.: +49 (0) 7152-203-77050
 garching.de@geze.com

GEZE GmbH
 Niederlassung Ost
 Böhrlingstraße 8
 13086 Berlin (Weissensee)
 Tel. +49 (0) 30-47 89 90-0
 Fax +49 (0) 30-47 89 90-17
 berlin.de@geze.com

GEZE GmbH
 Niederlassung Mitte/Luxemburg
 Adenauerallee 2
 61440 Oberursel (b. Frankfurt)
 Tel. +49 (0) 6171-63 610-0
 Fax +49 (0) 6171-63 610-1
 frankfurt.de@geze.com

GEZE GmbH
 Niederlassung West
 Nordsternstraße 65
 45329 Essen
 Tel. +49 (0) 201-83 082-0
 Fax +49 (0) 201-83 082-20
 essen.de@geze.com

GEZE GmbH
 Niederlassung Nord
 Haus 11, 1. OG - Theodorstr. 42-90
 22761 Hamburg-Bahrenfeld
 Tel. +49 (0) 40-2 19 07 16-27
 Fax +49 (0) 40-2 19 07 16-28
 hamburg.de@geze.com

GEZE Service GmbH
 Niederlassung Süd-West
 Reinhold-Vöster-Straße 25
 71229 Leonberg
 Tel. +49 (0) 1802-923392
 Fax +49 (0) 7152-92 33 63
 service-leonberg.de@geze.com

GEZE Service GmbH
 Niederlassung Süd
 Parking 17
 85748 Garching bei München
 Tel. +49 (0) 1802-923392
 Fax +49 (0) 89-120 07 42-60
 service-muenchen.de@geze.com

GEZE Service GmbH
 Niederlassung Mitte
 Oberurseler Str. 69
 61440 Oberursel
 Tel. +49 (0) 1802-923392
 Fax +49 (0) 6171-63 327-19
 service-oberursel.de@geze.com

GEZE Service GmbH
 Niederlassung West
 Nordsternstraße 65
 45329 Essen
 Tel. +49 (0) 1802-923392
 Fax +49 (0) 201-8 30 82-25
 service-essen.de@geze.com

GEZE Service GmbH
 Niederlassung Nord-Ost
 Böhrlingstraße 8
 13086 Berlin (Weissensee)
 Tel. +49 (0) 1802-923392
 Fax +49 (0) 30-47021733
 service-berlin.de@geze.com

GEZE Service GmbH
 Niederlassung Nord
 Theodorstr. 42-90, Haus 11
 22761 Hamburg
 Tel. +49 (0) 1802-923392
 Fax +49 (0) 40-219 07 16-19
 service-hamburg.de@geze.com

Austria
GEZE Austria
 Wiener Bundesstrasse 85
 A-5300 Hallwang
 Tel: +43/6225/87180
 Fax: +43/6225/87180-299
 austria.at@geze.com

Baltic States
GEZE GmbH Baltic States office
 Dzelsavas iela 120 S
 1021 Riga
 Tel. +371 (0) 67 89 60 35
 Fax +371 (0) 67 89 60 36
 office-latvia@geze.com

Benelux
GEZE Benelux B.V.
 Steenoven 36
 5626 DK Eindhoven
 Tel. +31 (0) 40-26 290-80
 Fax +31 (0) 40-26 290-85
 benelux.nl@geze.com

Bulgaria
GEZE Bulgaria - Trade
 Representative Office
 Nickolay Haitov 34 str., fl. 1
 1172 Sofia
 Tel. +359 (0) 24 70 43 73
 Fax +359 (0) 24 70 62 62
 office-bulgaria@geze.com

China
GEZE Industries (Tianjin) Co., Ltd.
 Shuangchenzhong Road
 Beichen Economic Development
 Area (BEDA)
 Tianjin 300400, P.R. China
 Tel. +86 (0) 22-26 97 39 95-0
 Fax +86 (0) 22-26 97 27 02
 sales-info@geze.com.cn

GEZE Industries (Tianjin) Co., Ltd.
 Branch Office Shanghai
 Unit 25N, Cross Region Plaza
 No 899, Ling Ling Road,
 XuHui District
 200030 Shanghai, P.R. China
 Tel. +86 (0) 21-523 40 960
 Fax +86 (0) 21-644 72 007
 chinasales@geze.com.cn

GEZE Industries (Tianjin) Co., Ltd.
 Branch Office Guangzhou
 Room 17C3
 Everbright Bank Building, No.689
 Tian He Bei Road
 510630 Guangzhou
 P.R. China
 Tel. +86 (0) 20-38 73 18 42
 Fax +86 (0) 20-38 73 18 34
 chinasales@geze.com.cn

GEZE Industries (Tianjin) Co., Ltd
 Branch Office Beijing
 Room 1001, Tower D
 Sanlitun SOHO
 No. 8, Gongti North Road,
 Chaoyang District
 100027 Beijing, P.R.China
 Tel. +86 (0) 10-59 35 93 00
 Fax +86 (0)10-59 35 93 22
 chinasales@geze.com.cn

France
GEZE France S.A.R.L.
 ZAC de l'Orme Rond
 RN 19
 77170 Servon
 Tel. +33 (0) 1 60 62 60 70
 Fax +33 (0) 1 60 62 60 71
 france.fr@geze.com

Hungary
GEZE Hungary Kft.
 Hungary-2051 Biatorbágy
 Vendel Park
 Huber u. 1.
 Tel. +36/23/532-735
 Fax +36/23/532-738
 office-hungary@geze.com

Iberia
GEZE Iberia S.R.L.
 C/ Andorra 24
 08830 San Boi de Llobregat
 (Barcelona)
 Tel. +34 902 194 036
 Fax +34 902 194 035
 info@geze.es

India
GEZE India Private Ltd.
 MF 2 & 3, Guindy Industrial Estate
 Ekkattuthangal
 Chennai 600 097
 Tamilnadu
 Tel. +91 (0) 44 30 61 69 00
 Fax +91 (0) 44 30 61 69 01
 office-india@geze.com

Italy
GEZE Italia S.r.l
 Via Giotto, 4
 20040 Cambiago (MI)
 Tel. +39 (0) 29 50 695-11
 Fax +39 (0) 29 50 695-33
 italia.it@geze.com

GEZE Italia S.r.l
 Via Lucrezia Romana, 91
 00178 Roma
 Tel. +39 (0) 6-72 65 311
 Fax +39 (0) 6-72 65 3136
 roma@geze.biz

Poland
GEZE Polska Sp.z o.o.
 ul. Annapol 21
 03-236 Warszawa
 Tel. +48 (0) 22 440 4 440
 Fax +48 (0) 22 440 4 400
 geze.pl@geze.com

Romania
GEZE Romania S.R.L.
 IRIDE Business Park,
 Str. Dimitrie Pompeiu nr. 9-9a,
 Building 10, Level 2, Sector 2,
 020335 Bucharest
 Tel.: +40 (0) 21 25 07 750
 Fax: +40 (0) 21 25 07 750
 office-romania@geze.com

Russia
OOO GEZE RUS
 Gamsonovskiy Per. 2
 115191 Moskau
 Tel. +7 (0) 495 933 06 59
 Fax +7 (0) 495 933 06 74
 office-russia@geze.com

Scandinavia - Sweden
GEZE Scandinavia AB
 Mallslingan 10
 Box 7060
 18711 Täby, Sweden
 Tel. +46 (0) 8-7323-400
 Fax +46 (0) 8-7323-499
 sverige.se@geze.com

Scandinavia - Norway
GEZE Scandinavia AB avd. Norge
 Industriveien 34 B
 2073 Dal
 Tel. +47 (0) 639-57 200
 Fax +47 (0) 639-57 173
 norge.se@geze.com

Scandinavia - Finland
Branch office of GEZE Scandinavia AB
 Herralantie 824
 Postbox 20
 15871 Hollola
 Tel. +358 (0) 10-40 05 100
 Fax +358 (0) 10-40 05 120
 finland.se@geze.com

Scandinavia - Denmark
GEZE Danmark
 Branch office of GEZE Scandinavia AB
 Mårkærvej 13 J-K
 2630 Taastrup
 Tel. +45 (0) 46-32 33 24
 Fax +45 (0) 46-32 33 26
 danmark.se@geze.com

Singapore
GEZE (Asia Pacific) Pte. Ltd.
 21 Bukit Batok Crescent
 #23-75 Wcega Tower
 Singapore 658065
 Tel. +65 6846 1338
 Fax: +65 6846 9353
 gezesea@geze.com.sg

South Africa
GEZE Distributors (Pty) Ltd.
 118 Richards Drive, Halfway House,
 Ext 111, P.O. Box 7934, Midrand 1685,
 South Africa
 Tel: + 27 (0) 113 158 286
 Fax: + 27 (0) 113158261
 info@gezesa.co.za

Switzerland
GEZE Schweiz AG
 Bodenackerstrasse 79
 4657 Dulliken
 Tel. +41 (0) 62 285 54 00
 Fax +41 (0) 62 285 54 01
 schweiz.ch@geze.com

Turkey
GEZE Kapı ve Pencere Sistemleri
 San. ve Tic. Ltd. Şti.
 Ataşehir Bulvarı, Ata 2/3
 Plaza Kat: 9 D: 84 Ataşehir
 Ataşehir / İstanbul
 Tel. + 90 (0) 216 455 43 15
 Fax + 90 (0) 216 455 82 15
 office-turkey@geze.com

Ukraine
LLC GEZE Ukraine
 ul. Viskoznaya, 17,
 Building 93-B, Office 12
 02660 Kiev
 Tel./Fax +38 (0) 44 501 22 25
 office-ukraine@geze.com

United Arab Emirates/GCC
GEZE Middle East
 P.O. Box 17903
 Jebel Ali Free Zone
 Dubai
 Tel. +971 (0) 4-88 33 112
 Fax +971 (0) 4-88 33 240
 geze@emirates.net.ae

United Kingdom
GEZE UK Ltd.
 Blenheim Way
 Fradley Park
 Lichfield
 Staffordshire WS13 8SY
 Tel. +44 (0) 1543 44 30 00
 Fax +44 (0) 1543 44 30 01
 info.uk@geze.com

GEZE REPRESENTATIVE